

MEETING MINUTES OF OPEN PUBLIC MEETING

BOARD OF DIRECTORS DIAMOND VALLEY WATER DISTRICT OFFICE (LEGAL SHIELD BUILDING) 1277 N. RHINESTONE, PRESCOTT, AZ

7:00 PM
Monday, June 13, 2016

CALL to ORDER

Chair Dave Cracknell called the **Public Hearing** to order at 7:02 pm.

ROLL CALL of BOARD MEMBERS P = PRESENT NP = NOT PRESENT

DAVE CRACKNELL (P) JEAN HEBERER (P) JO ANN HOLT (P)
KURT WOMACK (P) BILL HUNT (P)

Also present: Don Bohlier for District Management; 3 DV Members of the Public, and one guest.

PUBLIC HEARING 2016-2017 SERVICE FEES

1. Called To Order
2. Roll Call: all present.
3. Introduction of the Public Hearing by the Chair. Dave Cracknell highlighted: monthly service charges remain the same; system improvement surcharge remains the same; commodity rates were adjusted to reflect the increase from Prescott Valley; Hook up fee will be \$3,800; largest meter will be 2", if a need for larger size will be added as required; Service charge deposit raised to \$200, refunded after 12 months of good standing; application fee of \$30.
4. Comments from the Public. Barry McCoy thanked the Board for posting on the website.
5. Close of Public Hearing - adjournment.

PUBLIC HEARING 2016-2017 HOOKUP FEE

1. Called To Order
2. Roll Call: all present.
3. Introduction of the Public Hearing by the Chair. Brought down to \$3,800, read Resolution 2016-6-13 in Special Session.
4. Comments from the Public. Thanks.
5. Close of Public Hearing - adjournment.

PUBLIC HEARING 2016-2017 BUDGET

1. Called To Order
2. Roll Call: all present.
3. Introduction of the Public Hearing by the Chair. Dave Cracknell stated that it was posted on the website, and copies placed in box at church.
4. Comments from the Public. None, other than good job.
5. Close of Public Hearing - adjournment.

SPECIAL SESSION

1. Called To Order
2. Roll Call: all present.

ADMINISTRATIVE HOUSEKEEPING

No comments or discussion.

1. VERIZON UPDATE

D. Cracknell stated that accountant Stephen Crandall has been in contact with Verizon, they have ignored him. [M02.22.2016(R7pm) item 8; M03.16.2016(SS10.30am) item 3] Dave contacted former DVWD attorney Bill Whittington [M.1-17-2015 (1.00pm) item RESOLUTION 2015-1-5A] (who worked on the original contract) [Nov 24 2014 Ex Mtg Minutes, item 3.6.A], he is looking at our options, suggested a letter from Chair and/or attorney. Dave asked the Board for direction. J. Heberer suggested attorney *Whittington* start communication with Verizon, if no response, sue for CPA and legal expenses plus interest on \$2,500 owed.

D. Cracknell motioned use attorney Bill Whittington to rectify the breach of contract; seconded by J. Heberer.

APPROVED: 5-0.

2. PERMISSION FOR PROPERTY OWNER AT 5200 DIAMOND DRIVE TO ENCROACH ONTO ADJACENT DIAMOND VALLEY PROPERTY (5190 DIAMOND). DISCUSSION POSSIBLE SALE OF ABOVE MENTIONED DVWD PARCEL TO PROPERTY OWNER AT 5200 DIAMOND DRIVE

Sean Smith presented a Plot Plan (see below, right*) to show setback issue with the septic tank, which is placed on the side adjacent to the DVWD lot (east), asked for signature on Yavapai County exemption for encroachment, to move forward for permit application.

Well abandonment has been scheduled for upcoming Fiscal Year [M05.18.2016(SS10.30am) item 1.B], but still an issue for 100' distance to septic. The existing home on the other side (west) of DVWD lot appears to have similar encroachment issue. General opinion by Mr. Smith and K. Womack is the small lot size with the wash in back makes it reasonably unbuildable, unless there was a sewer system.

Discussion about selling: K. Womack asked about splitting the lot between owners each side, contingent upon having Mr. Smith buy the lot and doing the split/combining, and well abandonment. Kurt asked if Mr. Smith has funding to buy the lot; tentatively yes. J. Heberer requested DVWD attorney Kozak review and develop a contract. J. Heberer asked what the fair value is, arbitrary guesstimates based on recent sales, plus cost of well abandonment contingent upon treatment by Manager Bohler.; consideration of the District being non-profit.

D. Cracknell motioned to grant request for setback encroachment, letter to be signed, and to negotiate with Mr. Smith for sale of 5198 Diamond Dr. DVWD property; seconded by K. Womack.

APPROVED: 5-0.

3. RATIFY AND SIGN RESOLUTION R2016-6-13

D. Cracknell read the Resolution for hookup fees, rates charges. [DM05.23.2016(R7pm) item 6]
 D. Cracknell motioned to approve as read; seconded by J. Heberer. Signed.

APPROVED: 5-0.

CALL TO THE PUBLIC

Jodi Savage was concerned about previous meetings that she heard/read the District didn't need to sell the properties for the money. D. Cracknell stated this came up just last week. K. Womack explained about a previous transaction that he didn't feel was appropriate, but didn't object to [Nov 24 2014 Ex Mtg Minutes, 3.6.B]; this case is different. J. Heberer stated we are getting legal advice to proceed. D. Cracknell stated the AFO (Administration Financial & Operations) Manual does not address property transactions. Discussed the need to advertise the sale of lots. J. Heberer clarified the sale of lots was in Budget discussions, no income was included. [M04.13.2016(SS10.30am) item 1.B]

No other comments.

4. FUTURE AGENDA ITEMS - JUNE MONTHLY MEETING

Regular reports, 644/645 Turquoise, website update, Diamond Dr. legal opinion and follow-up, AFO Manual revisions, new Resolutions.

*



Information for Parcel 103-10-082:

Owner			
DIAMOND VALLEY WATER DISTRICT			
Owner's Mailing Address			
PO BOX 26527			
PRESCOTT VALLEY, AZ 863126527			
Secondary Owner			
N/A			
Recorded Documents & Sales (2)			
Date	Book/Page	Type	Cost
8/7/2009	4687/130	Other	\$0
4/20/1995	3003/1	Other	\$0
Parcel			
Improvements			
Assessment			

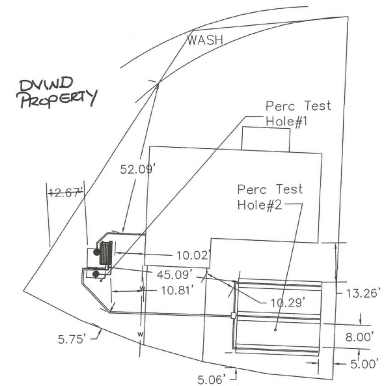

ADJOURNMENT

Meeting adjourned at 7:54 PM.

NOTE: [M00.00.2015] Indicates reference to Minutes from previous meetings.
 [aa] Robert's Rules Of Order.

Meeting Minutes prepared by Kurt Womack, Clerk/Secretary and made available on 6-28-16.

DRAFT to be APPROVED of these Meeting Minutes sent via email to all current Board Members and Management for review. Board approval to be an agenda item at the next scheduled DVWD REGULAR Meeting. In addition, two copies maintained and available in a file box at Permanent location at 1277 N. Rhinestone Dr., #2, Prescott, AZ 86301 in Diamond Valley for interested public.

An email copy of future DVWD Meeting Minutes and Agendas can be sent by requesting to be put on the electronic PerDVEmailRequest group list and providing an email address to: <http://diamondvalleywaterdistrict.com>

APPROVED ON: JUNE 27, 2016 by D. Cracknell, J.A. Holt, K. Womack, B. Hunt.